



**ModelMatic**

*De robot uit de mens halen: AI-gedreven  
procesoptimalisatie met ModelMatic*

***Vraag nu je gratis  
proefperiode aan!***



[www.modelmatic.nl](http://www.modelmatic.nl)

[Info@modelmatic.nl](mailto:Info@modelmatic.nl)

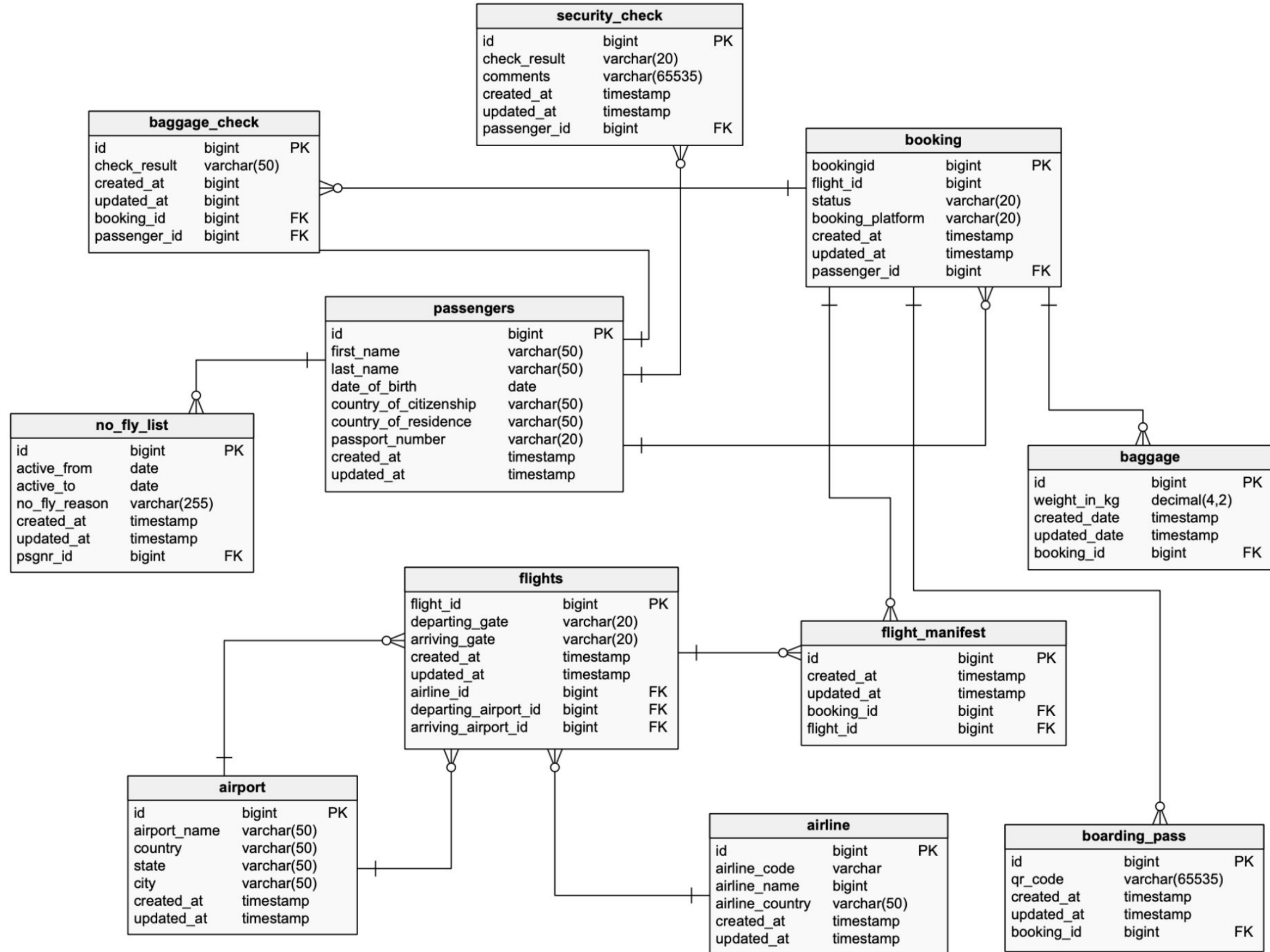

id
active
no_fly
creati
updat
psgnr

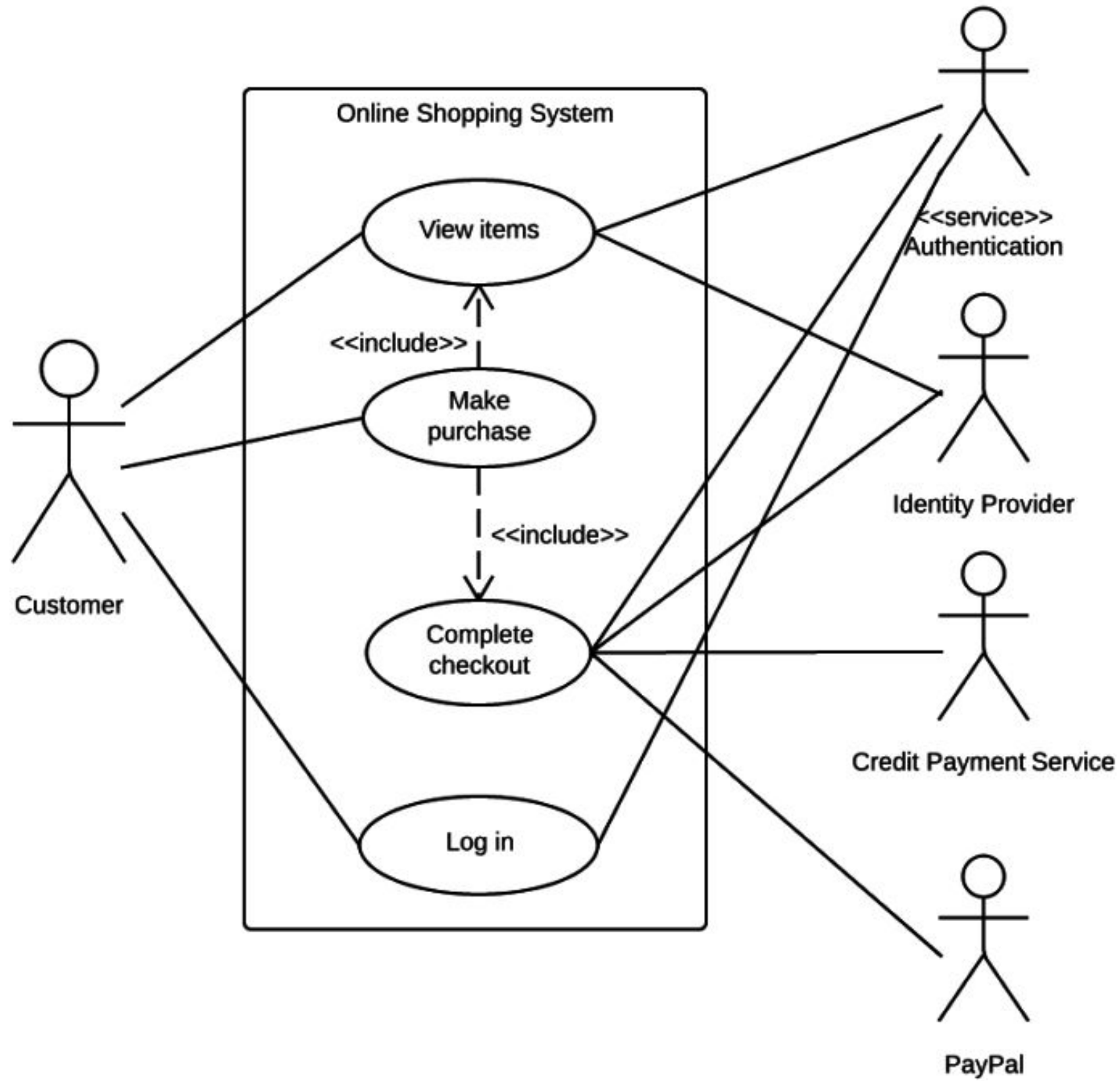

<
<

]
---



### Requirement Evolution

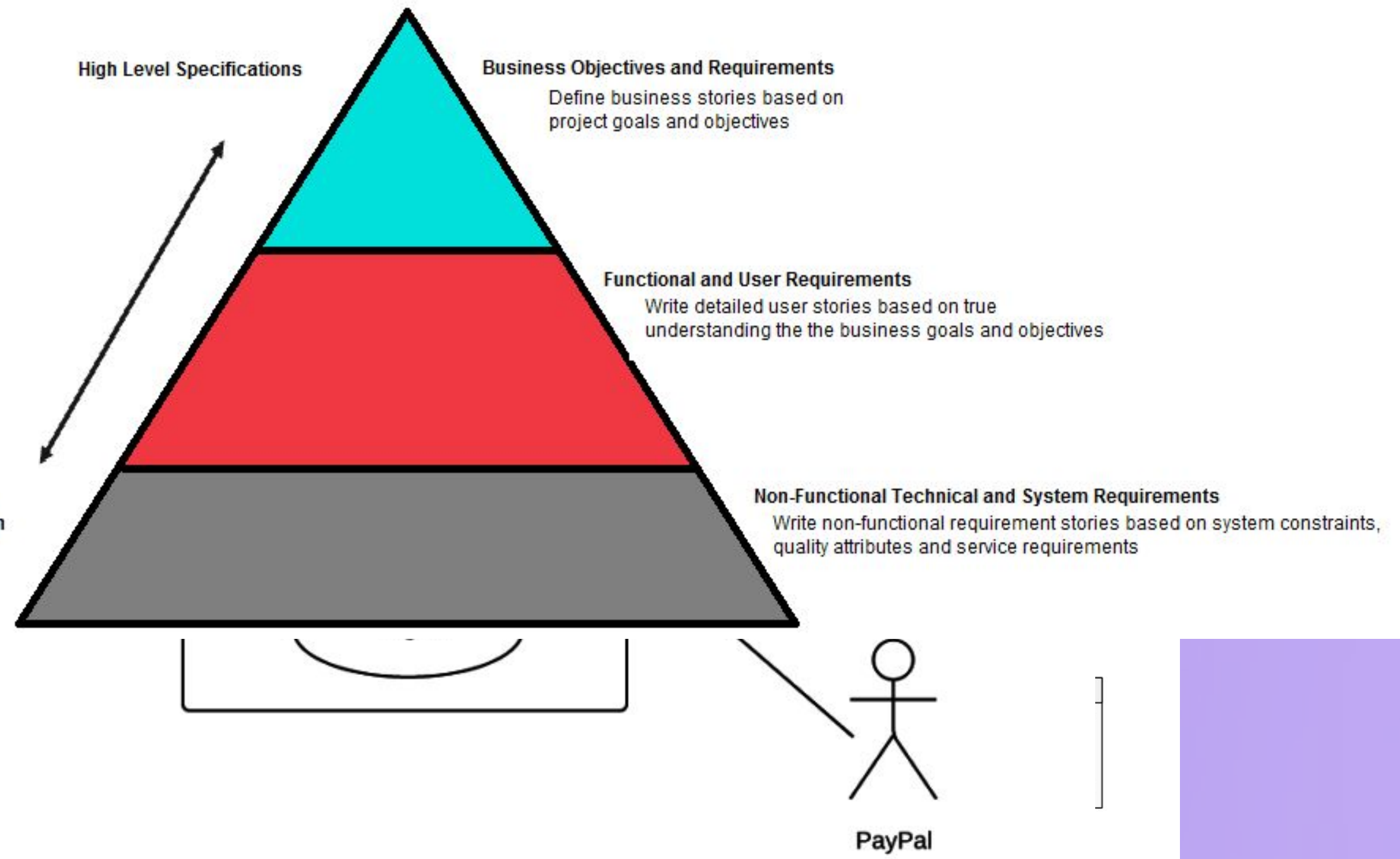



**Waarom maken we  
modellen?**

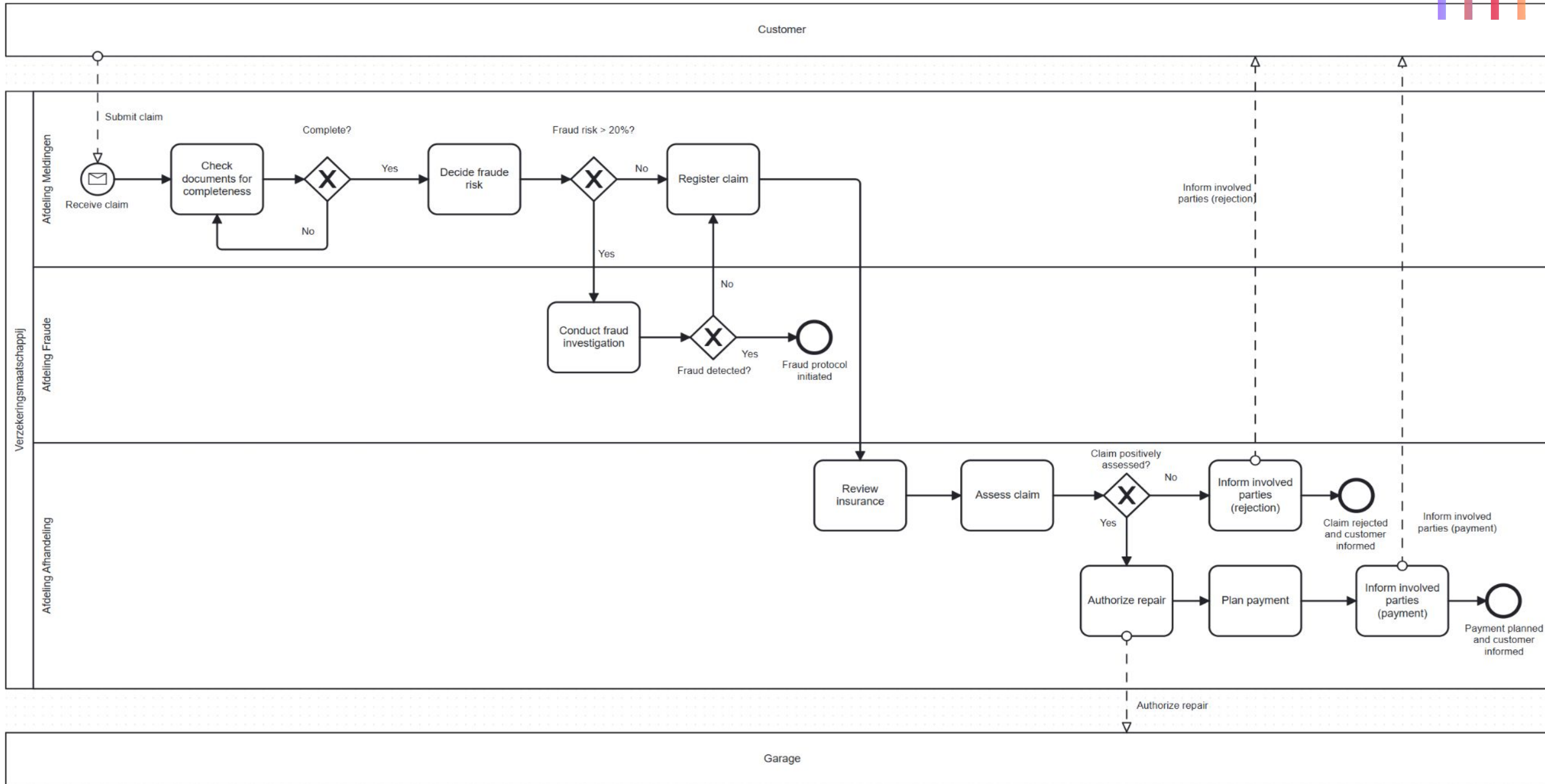

# **BPMN**

## **Blijven Prutsen Met Notaties**

# Verspilling in proces modellering



60% van  
BPM-projecten  
gaat naar  
procesmodellering.<sup>1</sup>

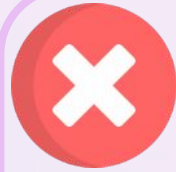

BA's zijn langer  
 bezig met het  
**middel** dan het **doel**.

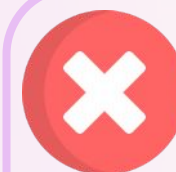

Goed vastleggen  
blijft **tijdrovend**.  
Procesmodellen  
worden slordig  
opgeleverd.



# Wat doet ModelMatic?

- 90% accurate proces diagrammen uit gesprekken én documenten
- 13+ talen ondersteuning
- Integraties via open standaard

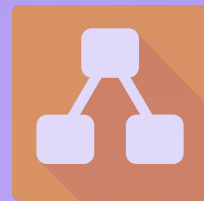

Bizzdesign



Signavio



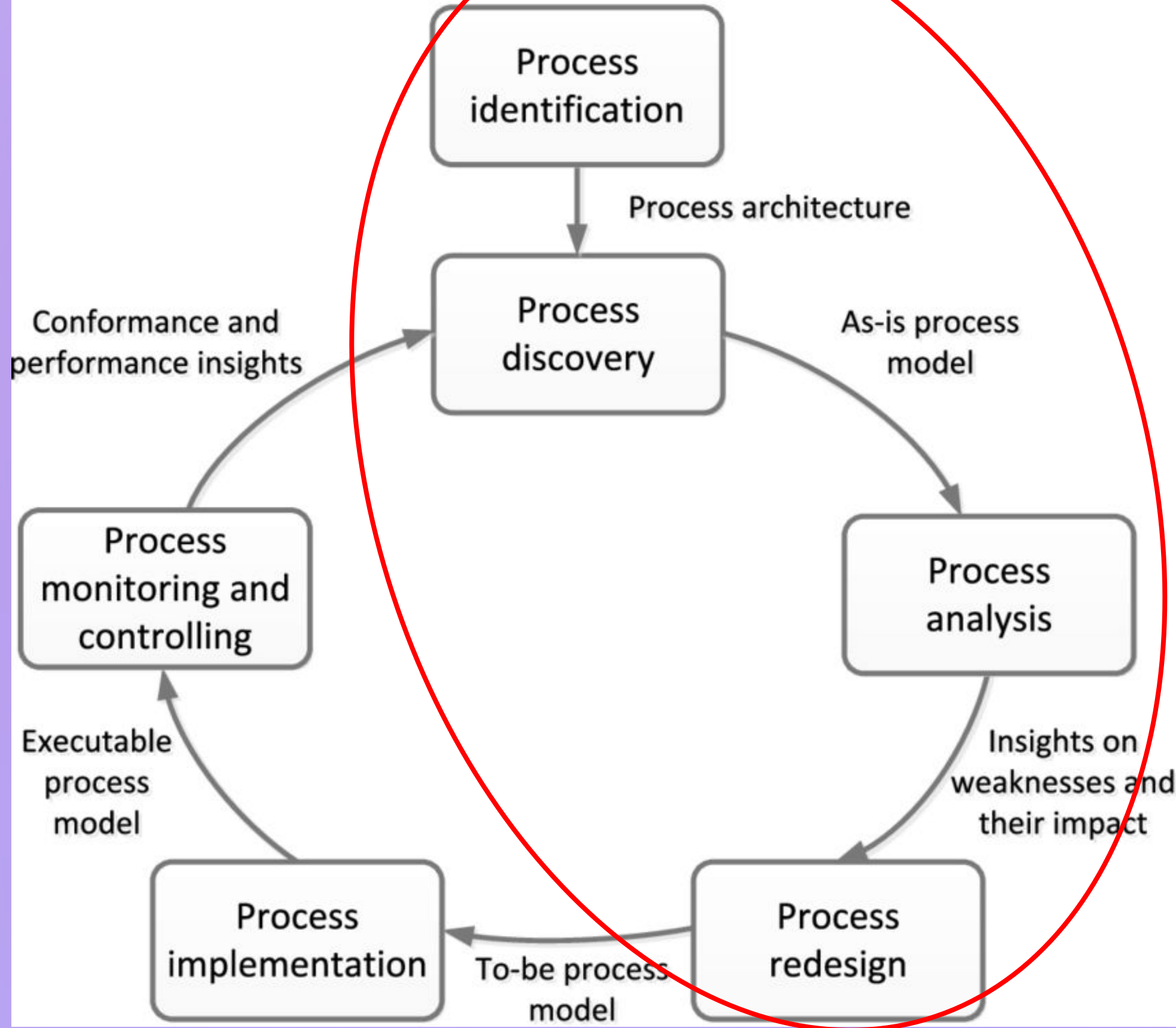

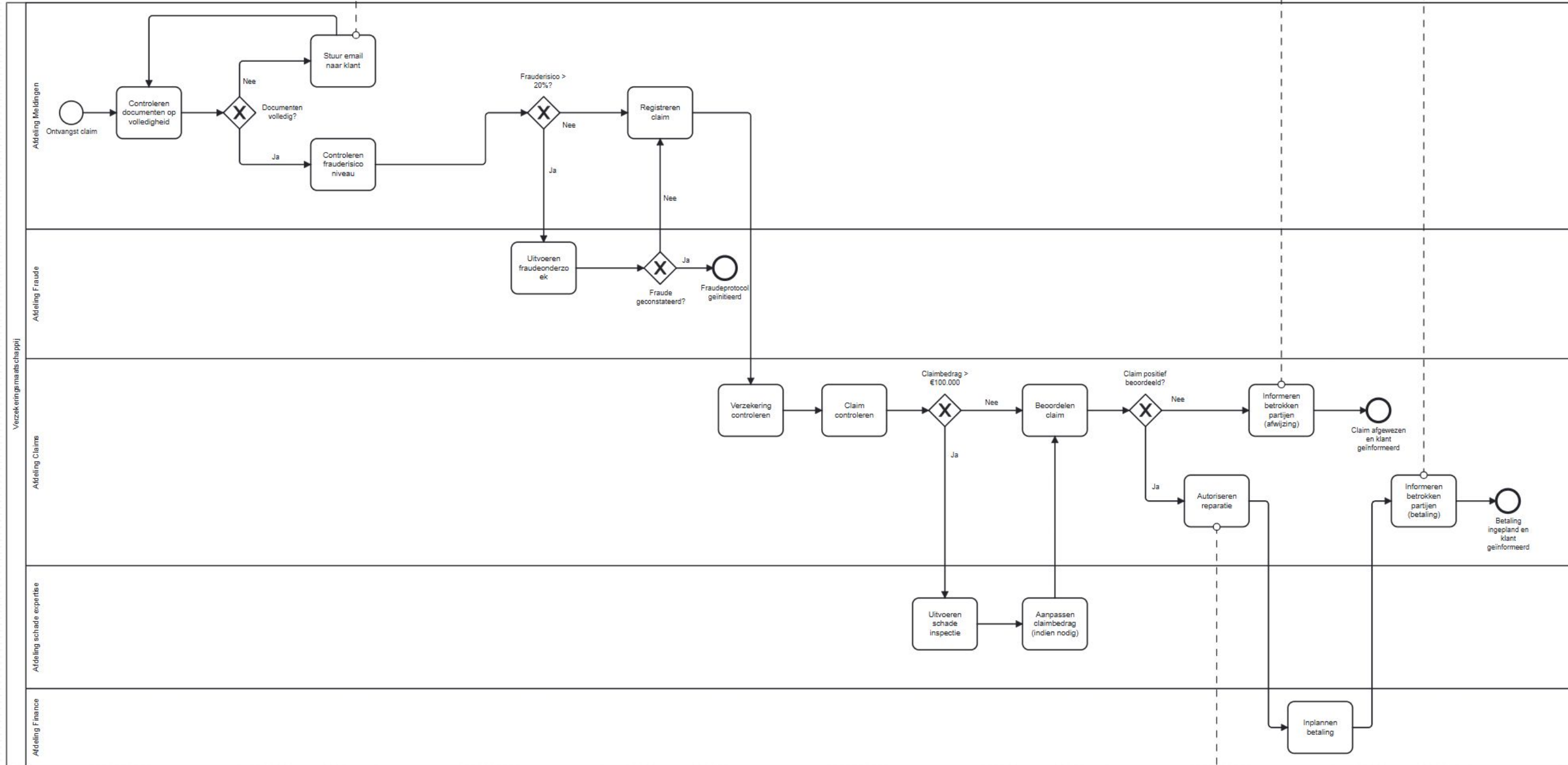

# Voordelen van ModelMatic



Bespaar tijd met geautomatiseerde procesdiagrammen



Verminder vervolgafspraken door directe validatie van stakeholders.



Zorg voor uniforme en kwalitatieve diagrammen bij alle collega's.



# Simulatie





# Spelregels



## Business Analist

- Ingehuurd voor optimalisatietraject
- As-is & knelpunten in kaart brengen
- Procesmodelleren

## Eigenaar pizzeria de Krokante Korst

- Eindverantwoordelijk voor inrichting & resultaat proces
- Heeft alle processen in haar hoofd

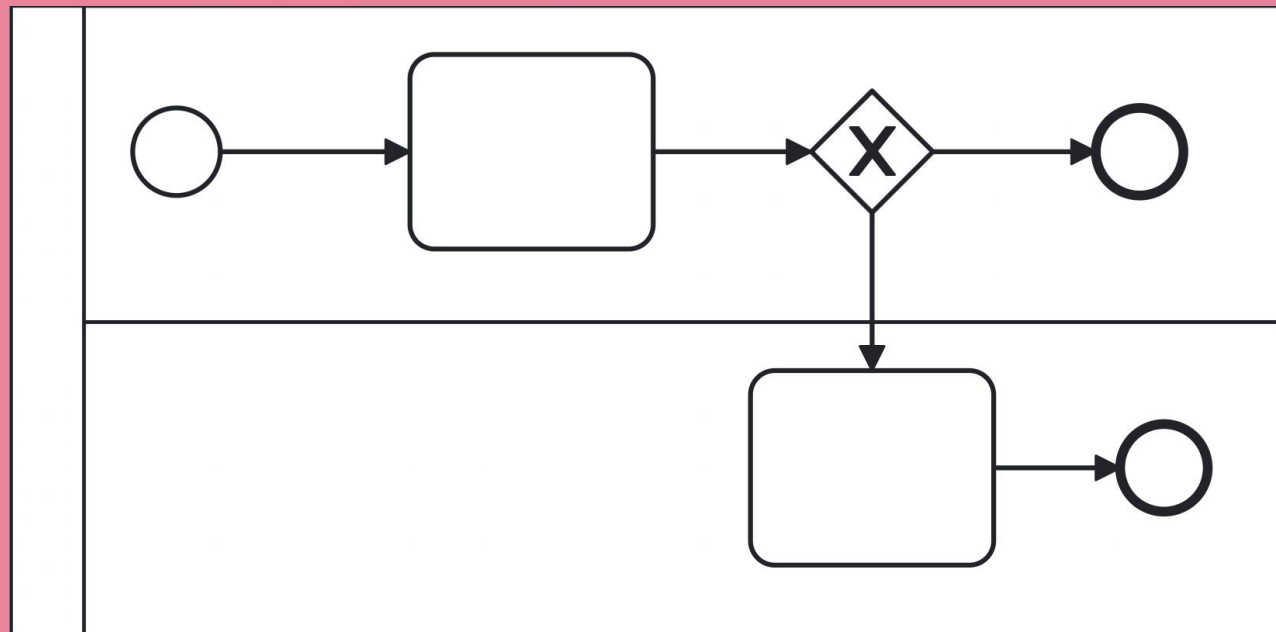



Pizzeria

Bezorger

Klant

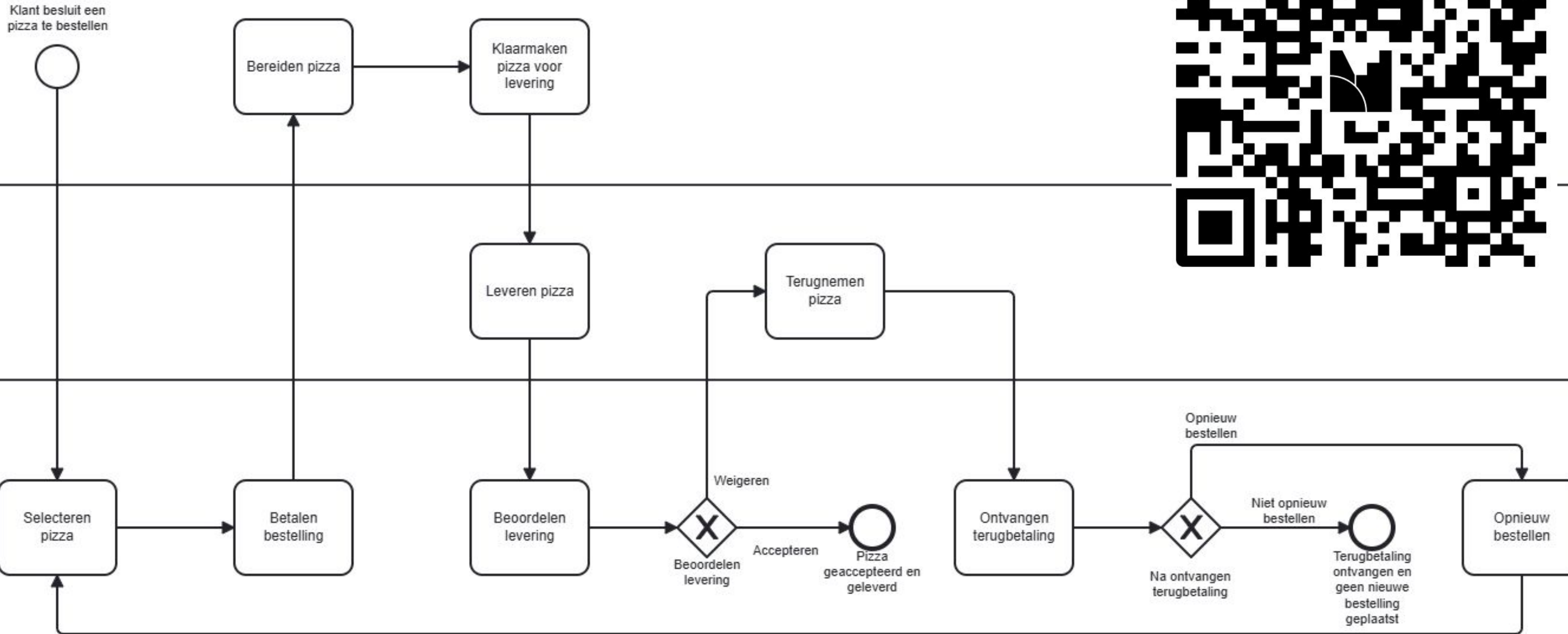

# Reflectie

- Geef het robotische werk uit handen
- Door samenwerking met AI menselijkheid versterken

# Demo



# De belofte van ModelMatic

**Efficiëntie**



**Effectiviteit**

# Key takeaways



- ✓ **ModelMatic geeft je de keuze**
- ✓ **Mensen moeten aan het roer blijven staan**

- ✓ **Taken worden geautomatiseerd, geen banen**
- ✓ **Meer ruimte voor menselijke inzichten. Samenwerken voorop**

Welke taken zou je  
morgen aan  
ModelMatic  
willen  
uitbesteden?



# Winactie gratis jaarlicentie

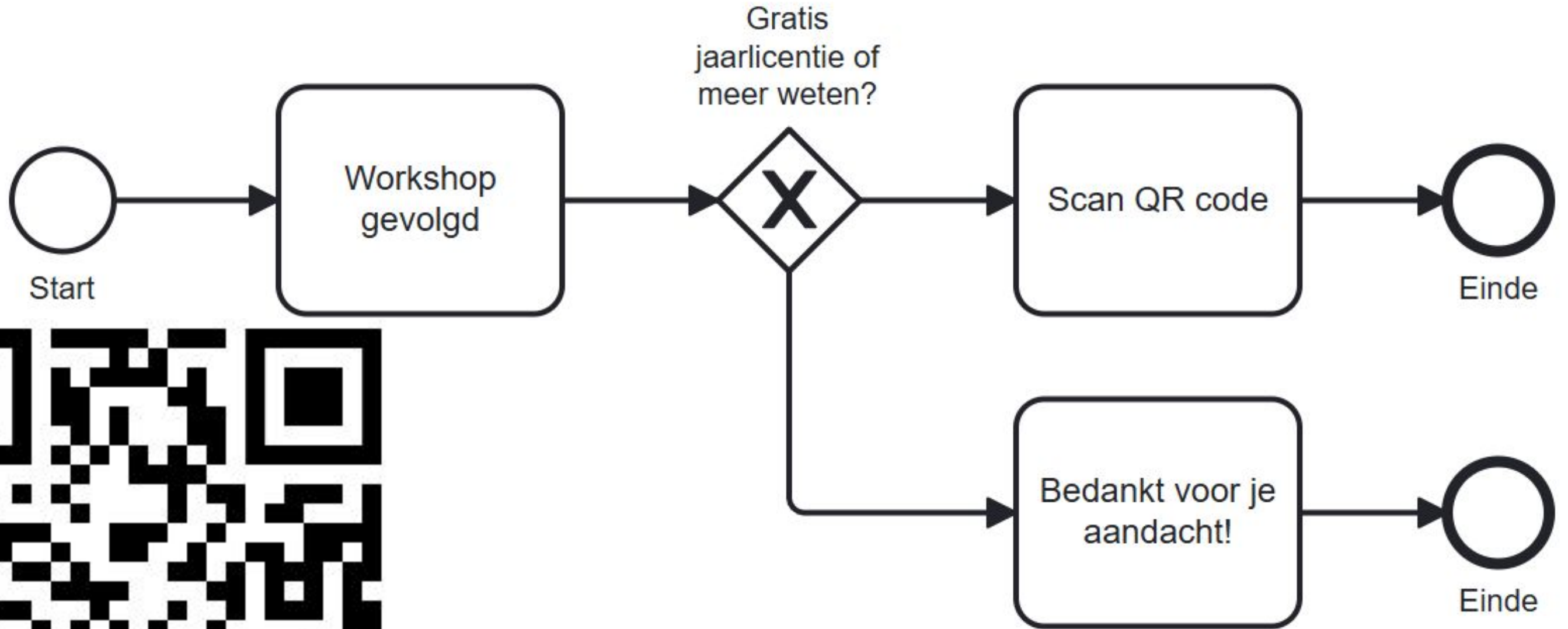

# Contact



**Thom Uffing**

COO

[Thom@modelmatic.nl](mailto:Thom@modelmatic.nl)



**Robbert Schuurmans**

CEO

[Robbert@modelmatic.nl](mailto:Robbert@modelmatic.nl)



**Simon Parmet**

CCO

[Simon@modelmatic.nl](mailto:Simon@modelmatic.nl)



[www.linkedin.com/company/modelmatic](https://www.linkedin.com/company/modelmatic)



[Info@modelmatic.nl](mailto:Info@modelmatic.nl)



[www.modelmatic.nl](http://www.modelmatic.nl)

# Hoe werkt ModelMatic

*Van dialoog naar diagram.*



Record Import

Kan je beschrijven wat je doet bij een binnenkomende factuur?

Natuurlijk, **via mijn mail ontvang ik alle facturen** Start

Wat doe je hier vervolgens mee?

Vervolgens **ga ik de facturen invoeren.** Taak

En wat gebeurd daarna?

**Dat hangt af van de hoogte van de factuur** Keuze wanneer deze meer dan 500 euro is stuur ik deze naar mijn leidinggevende.

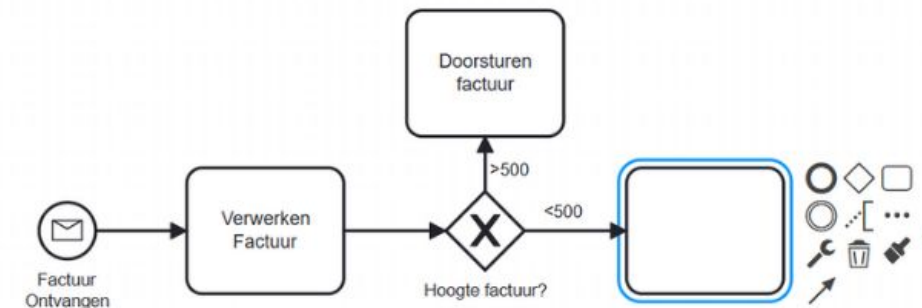
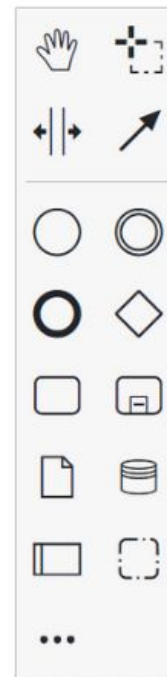

Export Save

Automatisch  
gegenereerd  
proces. Direct  
aanpasbaar

Beheer je  
processen  
in projecten  
of gebruik  
ze in je  
bestaande  
tools

Upload je  
meetings of  
neem ze in  
direct op

Essentiële  
informatie  
wordt direct  
gemarkeerd

✓ **AWS hosted**

✓ **EU-servers &  
versleutelde data**

✓ **ISO 27001 partners  
& BIO-2 compliant**

✓ **Data wordt NIET gebruikt  
voor  
AI-trainingsdoeleinden**