

Digital Twin als versneller van procestransformatie

Freek Hermkens, PhD

06-11-2025



Freek Hermkens

- ▶ **Principal business consultant MLC**
 - ▶ **> 25 years experience as consultant**
 - ▶ **Financial service industry / Housing association**
 - ▶ **Trainer and manager at MLC academy**
 - ▶ **Talent coach**
 - ▶ **PhD Role of middle management in achieving continuous improvement**
-

- **51 years old, Married and a son**
- **Utrecht**
- **Field hockey, Running and skiing**

Over MLC - Wij maken uw strategie werkbaar / uitvoerbaar

- ▶ Oppericht in 1986 (Molenaar & Lok Consultancy)
 - ▶ 2012 Martijn Tolsma en Robin Zwijnenberg
 - ▶ 2017 Agile Coach Company
 - ▶ 2024 IG&H samenwerking
- ▶ Gespecialiseerd 'boetiek' adviesbureau op het gebied van Digitale Proces Transformatie
 - ▶ *"Wij helpen organisaties te transformeren naar een (digitale) keten- en procesomgeving waarbij de mens in zijn kracht komt"*
 - ▶ Business Process Management, Agile, Continu Verbeteren, Proces Optimalisatie
- ▶ Samen met klanten werken aan optimale klantbeleving, excellente uitvoering en continue beheersing
- ▶ Hergebruik van inzichten, kennis en ervaringen binnen de verschillende sectoren waarbinnen wij opdrachten doen
- ▶ ~45 specialisten, consultants & projectleiders
 - ▶ Zakelijke dienstverlening
 - ▶ Woningcorporaties
 - ▶ Publieke sector
 - ▶ Handel, Logistiek & Industrie
- ▶ Onze kernwaarden: Sociaal Ondernemend
 - ▶ Samen sterk, Authentiek, Resultaat gedreven & Innovatief



Company profile IG&H

Fast-growing consultancy & tech firm with 35 years sector expertise

IG&H is fast growing with decades of sector expertise

35+
YEARS SECTOR EXPERTISE



PRIVATE EQUITY PARTNER SINCE 2022

650+
EMPLOYEES



OUR '23 & '24 ACQUISITIONS

98
OUT OF 100 CLIENTS SATISFIED





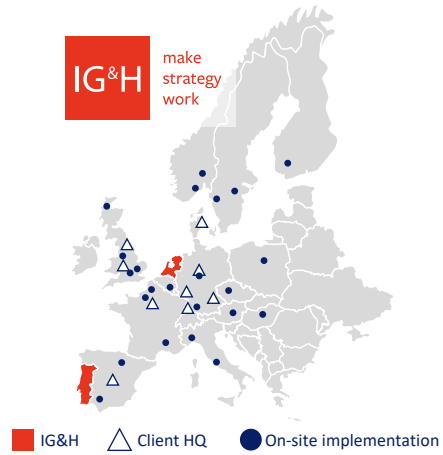

Our (long-term) clients

Health	Retail & Products	Financial services
PHILIPS	Radboudumc	JUMBO PLUS
Amsterdam UMC	Unilabs	pep
Zilveren Kruis	Erasmus MC	Boels
Landelijk netwerk acute zorg	Erasmus MC	LDE
	Erasmus MC	TP
		bol.
		Intergamma
		GA
		REMA
		WE
		PGGM
		achmea
		Blackstone
		PLANGROEP
		ING
		ABN-AMRO
		EGON
		Allianz
		Blackstone
		PLANGROEP
		achmea
		PGGM

All capabilities in-house for your digital transformation

Sector Expertise

- Retail & products
- Health
- Financial services

Digital Services

- Data & AI
- Process excellence
- Market intelligence
- Transformation
- Business engineering
- IT strategy & EA

Platform Services

- Low-code
- DevOps
- Integration
- Service Management
- Cloud & migration
- IT Operations

Our Tech partnerships:

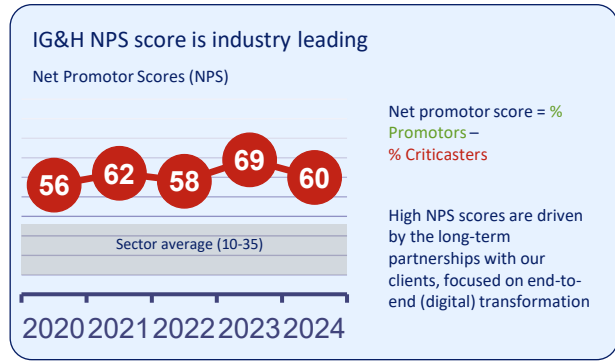



1. Onze visie op Digitale Procestransformatie

Onze visie op Digitale Procestransformatie

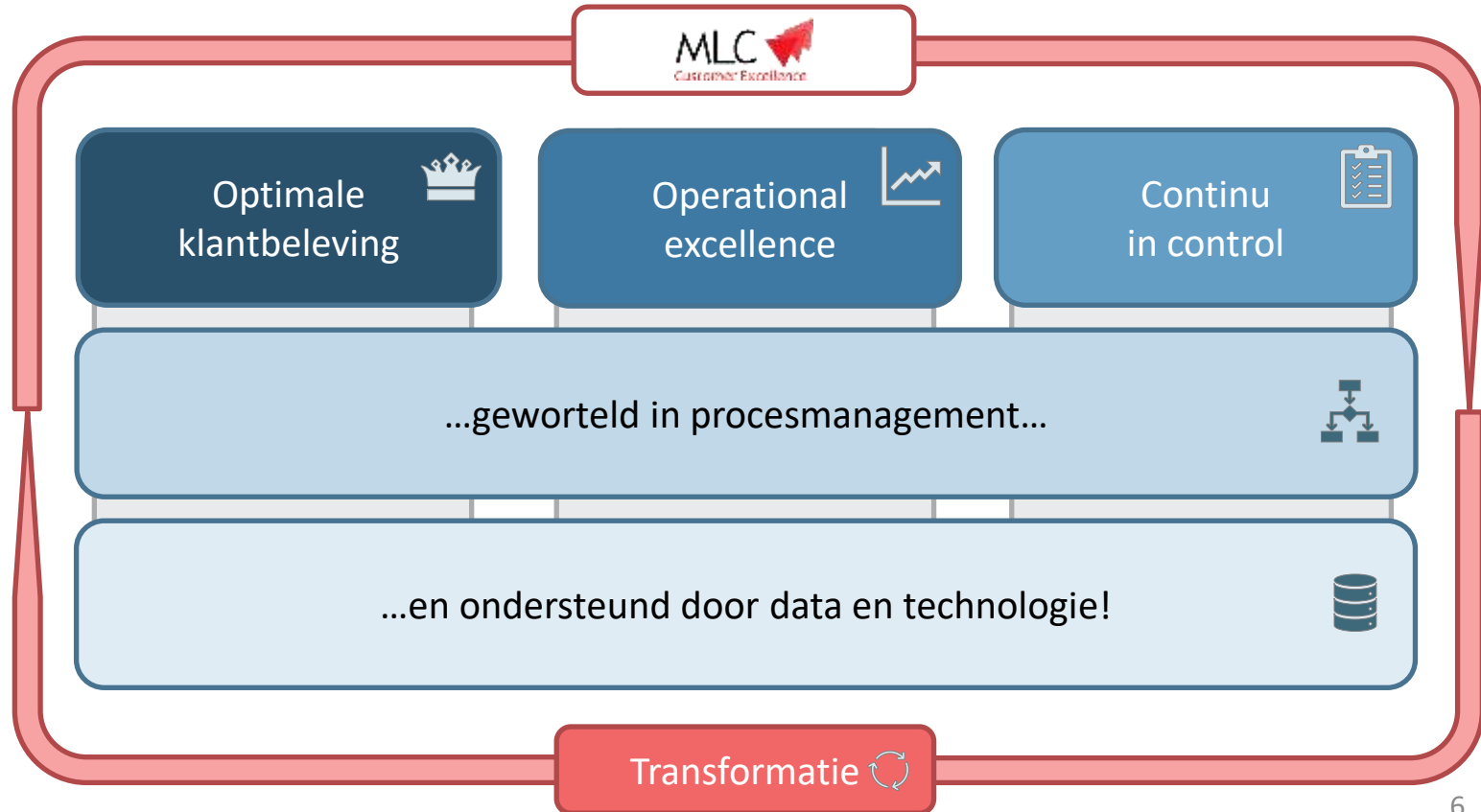

Overzicht vraagstukken

Business Process Management 	Optimale klantbeleving 	Operational excellence 	Continu in control 
Processen, organisatie, IT, compliance en risico's geïntegreerd managen	Integratie klantreizen met interne processen	Standaardiseren van processen ((GWOW en lokale varianten)	Monitoren van actuele prestaties processen
' Single source of truth ' voor business	Cascaderen van doelstellingen en KPI's	Optimaliseren van resource allocatie via effectief capaciteitsmanagement	Data-gedreven monitoren van risico's, compliance
Integratie andere systemen voor delen definities en managementinformatie	Managen van prestaties klant en leverancier middels proces dashboard	Verbeteren en automatiseren van processen	GRC by design
Ondersteuning, beheer en volgen van veranderingen	Inzichtelijk maken van ' cost to serve ' klanten	Inzicht krijgen in feitelijke uitvoering processen middels process mining	Procesverantwoordelijkheden, processturing en workflow



De Toekomst van Procesoptimalisatie

Digital Twins en slimme automatisering





Change is the only constant in life.
Ones ability to adapt to those changes
will determine your success in life.

Benjamin Franklin

Een **digital twin** is een exacte en dynamische **digitale kopie van de werkelijkheid**, die met **real time data** uit de echte wereld wordt gevoed om de **status van een bestaand object** of systeem te begrijpen en hierop te **reageren**.

MY PERSONAL
BODY
DIGITAL TWIN



Digital Twin als blauwdruk voor de organisatie van de toekomst

Gartner

“A digital twin of an organization (DTO) is a dynamic software model of any organization that relies on operational and contextual data to understand how an organization operationalizes its business model, connects with its current state, responds to changes, deploys resources and delivers customer value.”¹



¹ Gartner Market Guide for Technologies Supporting a Digital Twin of an Organization
4 January 2023, Author: Marc Kerremans, VP Analyst.



Digital Twin als sleutel voor Procesoptimalisatie

Digitized Resource Management

Toewijzing van middelen optimaliseren door het simuleren van personeelsmodellen (bijvoorbeeld op locatie versus op afstand) en het visualiseren van de impact ervan op productiviteit en kosten.

Duurzaamheid als Strategisch Doel

Duurzaamheid wordt een strategische focus voor bedrijven, waarbij technologische oplossingen worden ingezet om energieverbruik en afval te reduceren maar ook operationele kosten te optimaliseren.

Real-time & process-gedreven Risicomanagement

Simuleren van verschillende marktomstandigheden of operationele verstoringen, waardoor organisaties potentiële (compliance) risico's kunnen identificeren en strategieën voor mitigatie ontwikkelen.

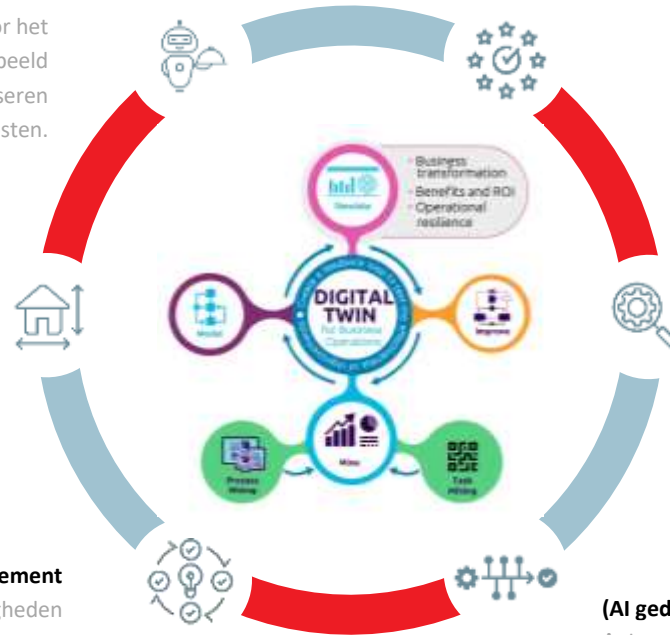

Data-gedreven Process Excellence

Continu verbeteren van klantreizen en bedrijfsprocessen op basis van real-time analyse en KPI monitoring. Process mining technologieën en AI ondersteunen hierbij door patronen in bestaande processen te analyseren optimalisatiemogelijkheden te signaleren.

Klantgericht procesontwerp

De klanten van vandaag verwachten snelle, soepele en gepersonaliseerde ervaringen, en BPM past zich aan om aan deze verwachtingen te voldoen.

(AI gedreven) Slimme automatisering

Automatisering wordt slimmer en specifieker door AI, waardoor processen sneller, accurater en meer geoptimaliseerd worden.



Data-gedreven Process Excellence

Digital Twin van het Proces (ontwerp)

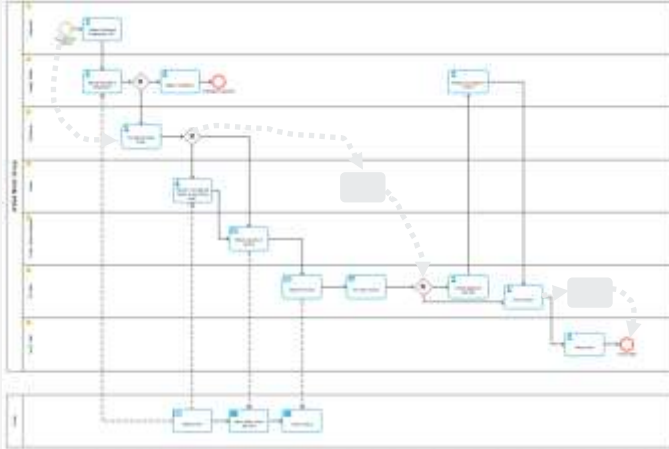

vs

Proces realiteit (executie)

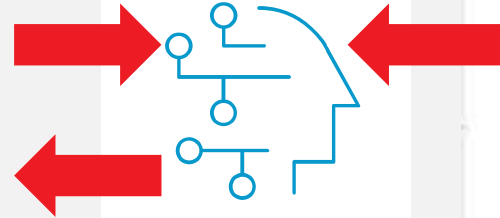
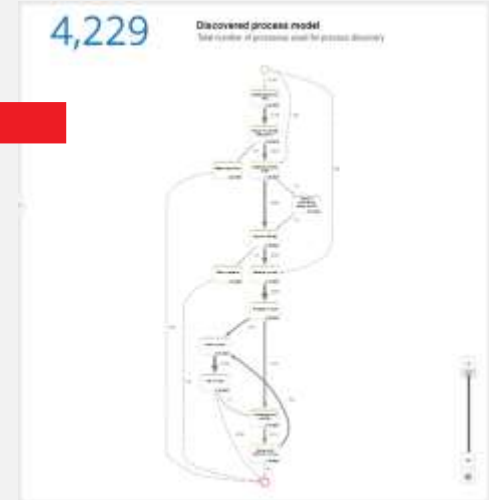

Process
Conformance
Checking



Digitized Resource Management

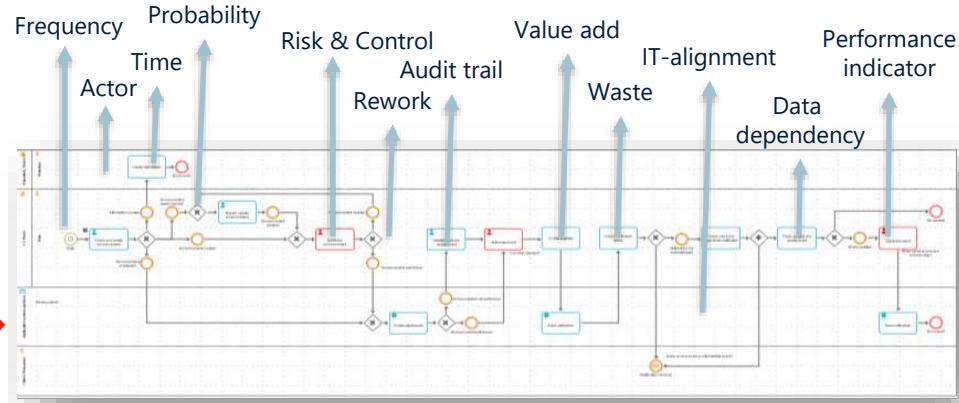

Integratie van **capaciteitsgegevens** in de procesomgeving voor **diepgaand inzicht** in gebruik, prestaties en verbeteringspotentieel van **middelen**.



Afzonderlijke componenten met statische en dynamische informatie

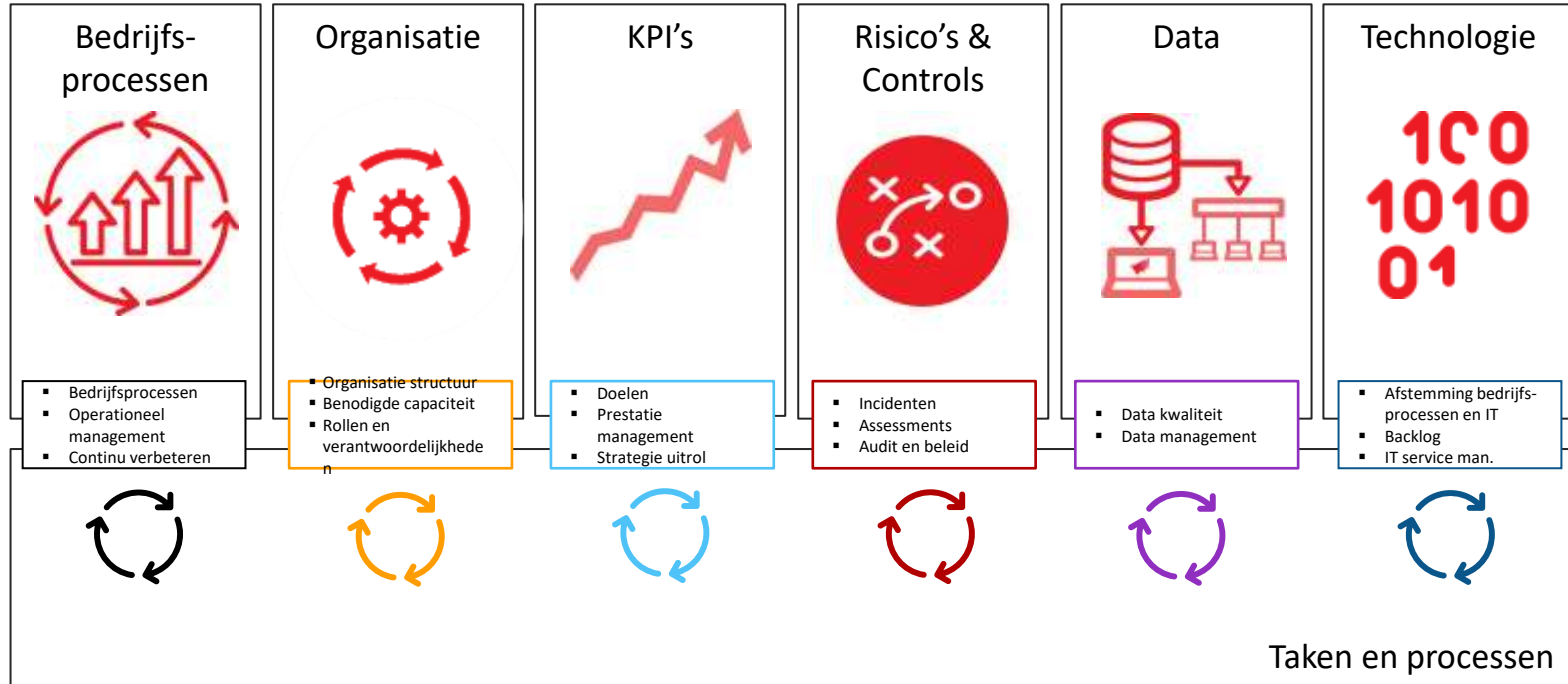

...vaak niet in samenhang opgepakt...

Structuur

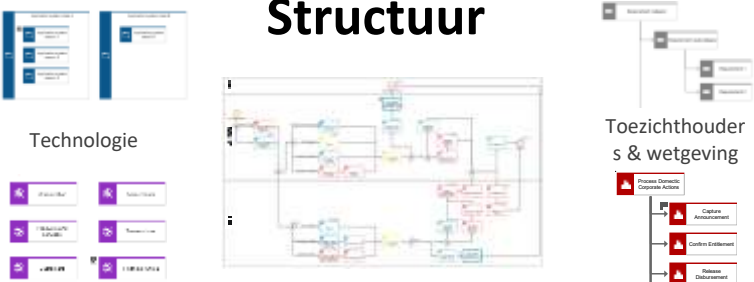

Technologie

Data

Bedrijfsprocessen

Toezichhouders & wetgeving

Risico's en mitigerende maatregelen

The diagram illustrates the organizational structure. It includes a 'Technologie' section with icons for various tools, a 'Data' section with icons for data sources, a central 'Bedrijfsprocessen' (Business Processes) flowchart, and a 'Toezichhouders & wetgeving' (Supervisors & Legislation) section with a tree diagram. Below this, a list of 'Risico's en mitigerende maatregelen' (Risks and Mitigating Measures) includes 'Process Domein', 'Compliance', 'Contract Enkement', and 'Process Disruptie'.

Inzicht



Performance (KPI's)

The image shows a dashboard with two large blue pie charts and a table below them, representing performance metrics (KPI's).

Verantwoordelijkheden



Organisatie

The image shows an organizational chart with a hierarchy of boxes representing different roles and departments within an organization.

Actie

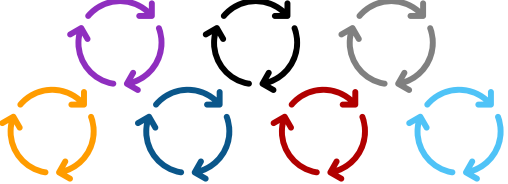

Taken en processen

The image shows a diagram with several circular arrows in different colors (purple, black, grey, orange, blue, red, light blue) arranged in a circular pattern, representing actions and processes.



Naar een geïntegreerde dynamische omgeving

Verantwoordelijkheden



Inzicht
door samenhang

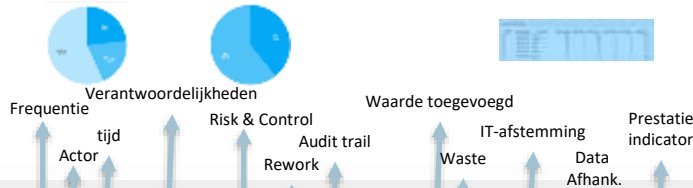

Actie

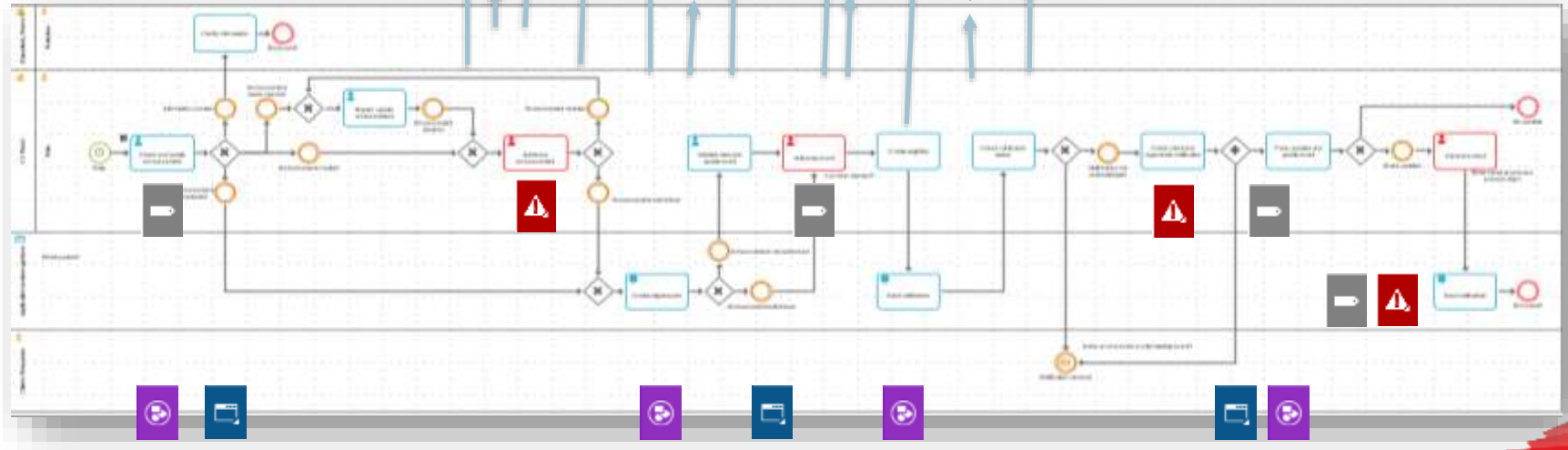
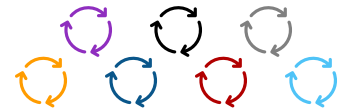

Structuur



Demo

Start



(EN)



De digital twin als versneller van procestransformatie



<https://www.consultancy.nl/nieuws/60923/de-digital-twin-als-versneller-van-procestransformatie>



Procesmanagement in het tijdperk van digitale transformatie



<https://document.igh.com/procesmanagementinhettijdperkvandigitale#page=1>



Vragen



Freek Hermkens
Principal Consultant

freek.hermkens@m-lc.nl
+31 6 55721082

